



# **RULES AND REGULATIONS**

**Last Revised: 6-7-2023  
7-13-2023**

# **WATER SERVICE RULES AND REGULATIONS**

## **OF THE**

## **OSCEOLA WATER WORKS**

## **OSCEOLA, IOWA**

### **PREFACE**

The Osceola Water Works is a municipal utility which is governed by, and officially titled as, The Board of Water Works Trustees of the City of Osceola, Iowa (“Osceola Water Works”). The Osceola Water Works delivers water to customers through water mains installed in public right-of-way and occasionally on easements on private property. The mains are either owned or maintained by the Osceola Water Works and are under its exclusive control. The water meter, automated meter reading devices and related wiring are installed and owned by the Osceola Water Works, but the customer remains responsible for protecting them from frost and other external forces. All water service is subject to these Rules and Regulations. No installation of a water service, nor repair thereof, shall be made which does not conform to these Rules and Regulations and the applicable plumbing code. All installations or repairs shall be made by a Licensed Plumber. Inspection for conformance by the Osceola Water Works or the appropriate jurisdictional plumbing inspector is required for all installations and repairs of water service facilities. Failure to comply with these rules and regulations may result in termination of the water service as hereafter provided. These Rules and Regulations shall take effect upon adoption by the Board of Water Trustees. The adoption of these Rules and regulations shall act to repeal or amend, as the case may be, any existing Rules and Regulations that are in conflict.

## TABLE OF CONTENTS

Definitions.....	4-5
Rule #1: Initiating Service and Service Rules.....	6
Rule #2: Water Deposits .....	6
Rule #3: Water Rates.....	7
Rule #4: Billing & Penalties .....	7-9
Rule #5: Labor Rates .....	9-10
Rule #6: Customer Responsibility .....	10-11
Rule #7: Water Leak Adjustment Policy .....	11
Rule #8: Meter & Tap Fees .....	12
Rule #9: Accepting Water Infrastructure Installed .....	12-13
Rule #10: Meter Installation .....	13
Rule #11: Meter Maintenance .....	13
Rule #12: Separate Meters Required .....	13
Rule #13: Sewer Deduct/Water Only Meters .....	13
Rule #14: Multiple Meters Located In One Dwelling .....	14
Rule #15: Access To Premises .....	14
Rule #16: Water Meter Testing Policy .....	15
Rule #17: Employee Compensation From Customers .....	15
Rule #18: Complaints .....	15
Rule #19: Right To Refuse Service .....	15
Rule #20: Location of Water Infrastructure .....	15-16
Rule #21: Unauthorized Use of Unmetered Water/Meter Tampering.....	16-17
Rule #22: Temporary Interruption Of Service .....	17
Rule #23: Temporary Service .....	17
Rule #24: Temporary Discontinuance Of Utility Services .....	17-18
Rule #25: Service Line Requirements .....	18-23
Rule #26: Hydrant Flow Testing .....	23-24
Rule #27: Use of Hydrant .....	24
Rule #28: Hydrant Meters .....	24
Rule #29: Obstruction Of Hydrants .....	24
Rule #30: Public Fire Hydrants .....	25
Rule #31: Private Fire Hydrants .....	25
Rule #32: Private Fire Protection .....	25
Rule #33: Penalties for Improper Use Of Fire Hydrant .....	25
Rule #34: Cross - Connection .....	26
Rule #35: Back Flow Prevention .....	26
Rule #36: Prohibiting Private Water Mains .....	26
Rule #37: Replacing Private Water Lines On Public Property.....	26-27
Rule #38: Water Main Replacements .....	27-29
Rule #39: Extension Of Mains Within The Corporate Area Of The City.....	29-32
Rule #40: Service Outside Of City Limits .....	32
Rule #41: Rights Reserved .....	32
Hydrant Permit .....	33-34
Meter Pit Spec .....	35-36
Service Line Abandonment Illustration.....	37-38

The following **DEFINITIONS** will identify the various terms used in the rules and regulations:

**AMENDED ON 7-1-2021 BY RESOLUTION 2021-08**

**A. CUSTOMER:**

Any person, firm or corporation, or any governmental division or department thereof, receiving water service from the Osceola Water Works.

**B. CUSTOMER'S SERVICE LINE:**

1. The service line between the curb box or meter pit at or near the property line and the structure(s) on the premises to be supplied. All expenses associated with the customer's service line shall be borne by the customer.
2. For any service line or service connection without a meter pit installed which complies with Osceola Water Works specifications, the customer shall be responsible to maintain and repair the service line and/or service connection from the premise to the main, which includes the curb stop and/or meter pit.
3. Each customer service line must be connected to a service connection that has its own separate tap in the water main.

**C. MAIN:**

The supply pipe, owned and maintained by the Osceola Water Works to which "Service Connections" are attached to supply water to one or more customers.

**D. METER:**

Is a mechanical device or devices owned by the Osceola Water Works which measures and records the quantity of water supplied to a Customer through a "Service Connection".

**E. PREMISES:**

As herein used shall designate:

1. A building under one roof owned or leased by a customer and occupied as a residence, or for business, industrial, or commercial purposes or;
2. A group or combination of building owned or leased by a Customer; occupied by one family, or one corporation or firm, as a residence, a place of business, or for manufacturing or industrial purposes, or as a hospital or other public service institutions; or
3. One side of a double house having a solid vertical partition wall; or
4. A building owned or leased by a Customer containing more than one apartment and having one entrance and using one hall in common; or

5. A building owned or leased by a Customer having a number of apartments, offices or lofts which are rented to tenants; or
6. A public building such as a town hall, school house, fire station, etc.; or
7. A single lot or park or playground; or
8. Each individual unit occupied by a single family or firm, in a continuous row with dividing walls common to two (2) units.

**F. PRIVATE SERVICE LINE:**

A service line owned by a customer(s) that contains one or multiple dwellings on one line that does not meet Osceola Water Works specifications.

**G. PRIVATE WATER MAIN:**

Water pipe, which supplies water to a specific premise or premises, owned by people or entities other than the Osceola Water Works.

**H. PRIVATE FIRE SERVICE CONNECTION:**

A pipe, with appurtenances, used to conduct water from the main to a customer's private fire protection system.

**I. SERVICE CONNECTION:**

1. A pipe with appurtenances owned by the Osceola Water Works used to conduct water from the main to a meter pit that meets Osceola Water Works specifications at or near the property line.
2. Service connections installed without an approved meter pit or vault meeting Osceola Water Works specifications are owned and maintained by the property owner. Service connections installed without the prior written approval of the Osceola Water Works is owned by the property owner from the main to the existing curb box or meter pit. All maintenance and repairs are the responsibility of the property owner.
3. Service connections will not be approved if the meter pit or curb box is connected to a private service line. Osceola Water Works retains the discretion to deny service connections that do not have an approved meter pit or curb box installed.
4. Each service connection must have its own tap in the water main.

**J. SERVICE UNIT:**

Any premises occupied by a single family, corporation or firm; each separate occupant of a multiple occupancy building or group of buildings.

**K. SEWER DEDUCT METER/WATER ONLY METER**

Meter that measures a portion of water which has already been metered by another meter for deduct billing purpose.

## **RULE 1: INITIATING SERVICE AND SERVICE RULES**

**Resolution 2022-04 dated 2-3-2022:**

**Resolution 2023-12 dated 5-4-2023:**

### **APPLICATION PROCESS:**

- A. Water service will be supplied only to customers who have signed an application of service form at the Osceola Water Works office. Signing of the water service form by a customer signifies their agreement to comply with these rules and regulations as they exist at the time of signing the contract, or as they may be later amended or changed.
- B. The customer or their agent shall present to the Osceola Water Works office a completed water application for service form and photo id. This application shall be applicable only to the premise specified, each subsequent or additional premise shall require a new application of service form. Each customer will be required to furnish the Osceola Water Works with their name, correct address, SSN or tax id and telephone number. If a customer has an unpaid balance or reconnection fee, either incurred at a prior location or another location presently being served by the Osceola Water Works for water service, this balance, and any applicable reconnection fee must be paid in full, before service can be activated.
- C. Any change in the identity of the contracting customer at a premise shall require a new application and the Osceola Water Works may discontinue the water supply until such new application has been completed and accepted.
- D. Customer's requesting to have their water services activated after regular business hours, will be charged a minimum fee of one hour at the standard hourly rate stated in rule 5 of Osceola Water Works Rules and Regulations.

## **RULE 2: WATER DEPOSITS**

**Resolution 2016-09 dated 3-3-2016:**

- A. If you are renting or purchasing a home on contract you will be required to pay a \$150 deposit before service is activated.
- B. In a rental or contract sale situation, service will remain in the property owner's name until the renter or contract sale customer (herein after referred to as customer) applies for service and pays a deposit. If a customer moves out without notifying the Water Works, service will remain in the customer's name until such time as the Water Works discovers the vacancy. Upon such time, service will automatically be returned to the owner's name or disconnected, and the deposit will be returned to the customer, less any outstanding charges.

- C. Customer deposits may be retained by Osceola Water Works until all efforts are exhausted in order to collect balances owed to Osceola Water Works for utility services.

**RULE: 3 WATER RATES**

**EFFECTIVE 7-1-2023**

**ADOPTED ON 6-1-2023, RESOLUTION #2023-17**

ALL AMOUNTS PER 1,000 GALLONS

RESIDENTIAL (FLAT RATE)	\$11.18
COMMERCIAL (0-50,000 GALLONS)	\$11.18
(50,000 GALLONS & UP)	\$10.56
INDUSTRIAL (FLAT RATE)	\$7.04
BULK WATER (FLAT RATE)	\$14.50

**RULE 4: BILLING AND PENALTIES**

**Resolution 2016-02 dated 1-7-2016:**

**Resolution 2021-10 dated 7-1-2021:**

Meters will be read periodically and bills for services will be rendered monthly to the customer, by the Osceola Water Works. When bills are rendered for a period of less than one (1) month because of the start or termination of service during the period, the charge shall be for the proportionate part of the applicable minimum charge, or the cost of the water consumed, whichever is the greater. Services terminated in less than thirty (30) days from the date of beginning shall be paid for on the basis of a full month's minimum bill or for the cost of the water consumed, whichever is greater.

Payment of bills may be made by mail, at the Osceola Water Works office located at 208 West Jefferson St., or at the drop box located in front of the building or in the parking lot by the alley. Payment may also be paid online at [www.osceolawaterworks.com](http://www.osceolawaterworks.com) All bills are due and payable upon their being mailed by the Osceola Water Works and will be considered as being delinquent if not paid within fifteen (15) days of the date of mailing.

**Penalties**

All accounts will receive a 10% penalty for any outstanding amounts owed after 4:00 p.m. on the 15<sup>th</sup> of the month. If a payment is made by our online payment website, it must be made by the 14<sup>th</sup> of the month for the payment to be considered on-time. A utility account holder that has received a penalty may request a one-time yearly waiver of the 10% penalty, if the account has been paid in full by the due date (15<sup>th</sup>) for a period of twelve months (one year) prior. The request needs to be submitted in writing to the Water Works office. If a waiver is granted, a credit will be placed on the utility account for the next available billing.

If the 15<sup>th</sup> of the month falls on a weekend or holiday, the penalty will be assessed after 4:00 p.m. on the first business day after the 15<sup>th</sup> of the month. If the payment is not received by the due date, the account will be subject to disconnection 12 days after the delinquent date. Osceola Water Works will place one telephone call to the customer of a commercial account

the day before the service is subject to disconnection. Customers are responsible for making certain current phone contacts are provided.

### **Reconnection Fees**

A charge of \$65.00 will be made to reconnect service after a disconnection for non-payment during normal business hours. A charge of \$85.00 will be made to reconnect service after regular business hours. A charge of \$130.00 will be made to reconnect service during holiday hours. Requests to reconnect water service after 7:00 p.m. will be processed the next day. Customers requesting to be reconnected after hours or during holiday hours shall be required to remit payment consisting of the entire balance of the account and the reconnection fee to Osceola Water Works no later than 12:00 p.m. the following business day or service will be again subject to disconnection.

A customer's water service which has been disconnected for non-payment will not be reinstated until the past due balance(s) including the reconnection fee(s) are paid in full at the Water Works office.

Osceola Water Works will not be responsible for stop boxes, discovered in the disconnection process to be in an inoperable condition or for stop boxes that may become inoperable when Osceola Water Works staff operates them during the disconnection or reconnection process.

Customers requesting their water service transferred to another residence will not be allowed to transfer the service until all past due balance(s) including applicable reconnection fee(s) are paid in full at the Water Works office.

### **Returned Payments**

There will be a \$45 charge for all returned payments.

Upon notification of a returned payment, Osceola Water Works will charge the payment back to the utility account and apply the \$45 charge. Written communication will be sent out from Osceola Water Works regarding the returned payment. The returned payment plus a \$45 charge will be required to be paid within twelve business days of the date the returned payment is received by Osceola Water Works. The timeframe for this payment is 12:00 p.m. on the twelfth day. Osceola Water Works staff will place a telephone call to the customer. A timeframe of up to 3:00 p.m. will be given. If the customer does not respond or pay by 3:00 p.m., the service will be disconnected. To get services reinstated, the customer must pay the balance owed plus the reconnect fee.

Upon receiving two returned payments within any given twelve-month timeframe, cash or credit/debit card payments will be required. A customer can request to use check payment methods after their account has been paid by the due date for a period of at least three months. The request needs to be submitted in writing to Osceola Water Works. If a payment method change is granted, the payment from the customer can not be returned for any reason, or the customer will be placed on cash only status for the lifetime of the account.



## **Payment Arrangements**

Osceola Water Works offers a customer the capability to extend their due date by filling out a payment arrangement form and paying half of the current bill. The customer may extend the payment amount three months as long as their current utility bill is paid by the 15<sup>th</sup> of each month (as stated on the payment arrangement form). The form is available for customers in the Water Works office, online and can be mailed, faxed or emailed.

If payment is not received by 8:30 a.m. the morning of the agreed time on the payment arrangement form, a call will be placed to the customer. A timeframe of up to 3:00 p.m. will be given. If the customer does not respond or pay by 3:00 p.m., the service will be disconnected. To get services reinstated, the customer must pay the balance owed plus the reconnect fee.

### **RULE 5: LABOR RATES**

**Resolution 2015-13 dated 9-8-2015:**

**Resolution 2021-11 dated 7-1-2021:**

Osceola Water Works will charge fees for performing work for Water Works customers as listed below.

**LABOR:** Standard Hourly Labor Rate \$68.00/hour/employee

Overtime Hourly Labor Rate \$101.00/hour/employee

Other labor charges for work completed by Osceola Water Works may be calculated based upon specific wage rates with the appropriate multiplier in lieu of the standard hourly rate.

### **MISCELLANEOUS CHARGES FOR EQUIPMENT SERVICES (THE BELOW CHARGES WILL BE PRO-RATED BASED ON ACTUAL TIME.):**

Service Vehicle \$20.00/hour

Dump Truck \$65.00/hour

Backhoe \$50.00/hour

Skid Loader \$45.00/hour

Concrete Saw \$40.00/hour

Air Compressor \$20.00/hour

Concrete Breaker \$35.00/hour

Water Pump \$15.00/hour

Hydro-Vac \$65.00/hour

### **FEES FOR DISCONNECTION REQUESTS AFTER HOURS:**

When requested by the customer, the Water Works will cause the water to be turned off at the curb stop, provided the curb stop is in working order and is accessible. If an additional trip is required after regular working hours to reconnect service, a fee of one hour at the

standard hourly rate stated in rule 5 of Osceola Water Works Rules and Regulations will be charged to the customer for this service.

The cost of locating and servicing an inaccessible or damaged curb stop or curb box will be at the expense of the customer ordering discontinuance of service. Should it become necessary to cut off water at the corporation cock in the main, the expense thereof shall be charged to the owner of the premise.

**LABOR FOR FILLING RAILCAR OR TRUCK TANKERS:**

Osceola Water Works agrees to assist the railcar and/or truck tankers at the rate of \$68.00/hour during regular business hours in addition to the cost of water at the bulk water rate and \$130.00/hour in addition to the cost of water at the bulk water outside after regular business hours.

The Osceola Water Board of Trustees, from time to time, may establish, abolish, or change miscellaneous charges for services and/or equipment provided to its customers. These charges shall be reviewed periodically and based as much as possible on costs of service.

**ADMINISTRATION FEE FOR CONTRACTED STOP BOX REPAIR**

**Resolution 2020-04 dated 4-2-2020:**

A \$100.00 fee will be charged to customers when stop box repairs are completed by Osceola Water Works contracted plumber.

**RULE 6: CUSTOMER RESPONSIBILITY**

- A. Payment of bills may be made by mail, during regular business hours at the Osceola Water Works office located at 208 West Jefferson St., or at the drop box located in the South parking lot. Payment may also be paid online at [www.osceolawaterworks.com](http://www.osceolawaterworks.com)
- B. Where water is supplied to several parties in apartments, offices or stores all located in a single building and supplied through one meter, only one party will be responsible for the payment of the water bill.
- C. Failure to receive bills or notices will not be considered an excuse for non-payment nor reason to permit an extension of the date when the amount would be considered delinquent.
- D. A Customer who has made application for water service to a premise shall be held liable for all water service(s) furnished to such premise until such time as the customer fills out a disconnection of service form at the Osceola Water Works office.
- E. Customers shall be responsible for paying the total amount for metered water regardless of any leaks or unintended use of water which may have occurred during the period of use.

- F. The customer shall protect and safeguard water service pipes and fixtures. The owner, at his/her expense, must keep service pipes and all appurtenances in good working order. The Osceola Water Works is not responsible for customer's service pipes and fixtures. No claims shall be made or maintained against the Osceola Water Works for damages due to the breakage of any service pipes or appurtenances, nor for accidental failure in the supply water.

**Resolution 2016-13 dated 6-9-2016:**

If a grade change or other changes to the property result in a change in elevation, the property owner shall raise or lower the meter pit, curb box and/or water hydrant to match the new elevation. Should the owner fail to regrade the property, or if the work is improperly done, Osceola Water Works shall have the right to complete or correct the work, and the costs thereof shall be assessed to the property owner to be collected with and in the same manner as general property taxes.

**G. Resolution 2014-16 dated 10-2-2014:**

Whenever it shall come to the attention of the Osceola Water Works that a property owner's water service, curb box, meter pit or valve (including its cover) is broken, inoperable, or otherwise in a dangerous or unsafe condition, the Osceola Water Works will make reasonable efforts to notify the occupant of the premise and, if different, the customer and the person in whose name the property is taxed. Upon such notification, the property owner shall be required, at the discretion of the Osceola Water Works, to immediately repair or replace the facility. The discretion of the Osceola Water Works includes the discretion to direct that an inoperable curb stop to be replaced with a meter pit at the expense of the property owner. For any such owner's appurtenance connected to the Osceola Water Works' distribution system, the Osceola Water Works may terminate water service to the premises until such repairs are made or, in case such condition poses a hazard to the public or adjoining property, it may make or cause such repairs to be made immediately without notice to the occupant and/or property owner(s). The costs of such termination and repairs, including materials, shall be billed to the property owner and, if not paid, shall result in termination of service to the premises or the certification of such amount as a lien against the property as with other unpaid water bills.

**RULE 7: WATER LEAK ADJUSTMENT POLICY**

**Resolution 2014-15 dated 9-11-2014:**

The Osceola Water Board of Trustees set a leak adjustment policy for use when dealing with customers who experience an overage in water fees due to excessive use.

- If the water portion of the utility bill is \$0 to \$100.00, the customer will be responsible for the entire bill and no water adjustment will be granted.
- If the water portion of the utility bill is over \$100.00, a consumption report will be provided to the Water Board of Trustees. The Water Board of Trustees may consider reducing the costs of excessive gallons based on the consumption report to the Osceola Water Works current production costs. All customers requesting water leak

adjustments will be required to present a written request and may make an oral presentation to the Osceola Water Board of Trustees.

Any adjustment authorized will be at the sole discretion of the Osceola Water Board of Trustees. The decision made by the Osceola Water Board of Trustees will be final with no appeal process.

**RULE 8: METER AND TAP FEES**

**Resolution 2023-03 dated 2-2-2022:**

New service fees/meter fees shall be paid by the customer and are as follows:

*Water Main Connection Fee must be paid before water main is tapped.*

**Water Main Connection Fee:**

¾" to 1" = \$500.00  
1 ½" = \$600.00  
2" = \$700.00  
4" = \$750.00  
6" & Larger = \$850.00

*Meter fees are as listed below:*

½" x 5/8" = \$428.00  
¾" x 5/8" = \$454.40  
¾" = \$460.40  
1" = \$612.80  
1 ½" = \$962.00  
  
1" E Series = \$692.60  
1 ½" E Series = \$1,240.40  
2" E Series = \$1,544.00  
½" x 5/8" Brass Base (Household) = \$152.00  
¾" x 5/8" Brass Base (Meter Pit) = \$152.00  
¾" Brass Base = \$195.20  
1" Brass Base = \$333.20  
1 ½" Brass Base = \$668.80

*Meters 2" or larger will be charged based on current meter prices & Water Superintendent's review of requested water demand.*

**Frozen Meter Fee:** All frozen meters will be charged based on current meter fees above.

Customers requesting to replace frozen water meters after normal business hours, will be charged a minimum fee of one hour at the standard hourly rate stated in Rule 5, labor rates of the Osceola Water Works Rules and Regulations.

**RULE 9: ACCEPTING WATER INFRASTRUCTURE THAT HAS BEEN INSTALLED TO OSCEOLA WATER WORKS SPECIFICATIONS**

**Resolution 2016-14 dated 6-9-2016**

For new developments within the City of Osceola, Iowa, when it is determined that:

- 1) All work as constructed meet Osceola Water Works' standards,
- 2) All documentation for the work has been completed
- 3) A meter has been installed by Osceola Water Works

Osceola Water Works will accept ownership of the new fire hydrant(s), water main, service connection(s) and meter pit(s) from the developer. After transfer of ownership from developer to Osceola Water Works, the property owner remains responsible for keeping the water infrastructure at grade level and undamaged.

**RULE 10: METER INSTALLATION**

The Osceola Water Works shall provide and install all meters to Osceola Water Works specifications. After the initial meter purchase, the Osceola Water Works shall purchase and install replacement meters at such times as are determined by the Osceola Water Work.

**RULE 11: METER MAINTENANCE**

The Osceola Water Works shall repair and maintain meter(s) on or at the customer's premises; provided, however, that if the meter is damaged (including damage by freezing or by hot water backing into meter) by the customer or representatives of the customer, the cost of such repairs or replacement shall be paid by the customer.

**RULE 12: SEPARATE METERS REQUIRED**

On all services, each meter installed to serve a separate customer's service shall be considered as a separate customer and shall be billed as a separate customer except in those cases where the Osceola Water Works has made additional meter installations for its own convenience in determining the amount of water delivered.

**RULE 13: SEWER DEDUCT/WATER ONLY METERS**

**Resolution 2015-22 dated 9-8-2015.**

**Resolution 2020-13 dated 8-13-2020.**

Sewer deduct meters are meters that measure a portion of the water which has already been metered by another meter for deduct billing purposes. The installation of these meters will be performed as permitted by Osceola Water Works for the purpose of measuring water not returning to the sewer system and pursuant to City of Osceola Code of Ordinance No. 621 Section 99.07 METERED WATER WHICH DOES NOT ENTER THE SEWER SYSTEM.

All maintenance, repairs, testing and future meter replacement of the sewer deduct meter will be completed by Osceola Water Works at the customer's expense. Meters are required to be purchased through Osceola Water Works in order to ensure that they are readably compatible with Osceola Water Works reading and billing systems. Customers desiring to purchase a deduct meter will be required to obtain a plumbing permit through the City of Osceola before purchasing a meter. All meter installations shall be subject to the International Plumbing Code and shall be permitted and inspected by the City of Osceola and Osceola Water Works.

**RULE 14: MULTIPLE METERS LOCATED IN ONE DWELLING**

**Resolution 2020-08 Amendment dated 10-1-2020:**

All Multi-Unit properties constructed or renovated after June 4, 2020 are required to be metered under one of the two options listed below:

Option 1. Per Unit Metering. Each dwelling unit in a Multi-Unit building shall be serviced by a dedicated water meter. Meters shall be installed pursuant to the Osceola Water Works Rules and Regulations. Each individual water service shall be required to have a separate stop box or meter pit. The decision of whether to install a meter pit or curb box shall be at the sole discretion of the Osceola Water Works. Osceola Water Works shall be granted perpetual legal access to the stop box, meter pit and meter. No master meter shall be installed.

Option 2. Master Meter. A master meter shall be installed, and the property owner shall be financially responsible for all metered usage.

On any premise having more than one service unit, or business, all of which are serviced by a single meter, the domestic minimum rate shall be multiplied by the number of such service units or businesses taking water from the same meter whether the units are occupied or not. This paragraph does not apply to rooming houses, hotel or motels.

Failure to provide either option 1 or 2 will require the utility bill to be left in or transferred to the landlords name for billing purposes and a water exemption will not be accepted.

Existing Service. All existing Multi-Unit properties constructed or renovated on/before June 4, 2020 and which have provided Osceola Water Works perpetual access to a secured meter room shall continue to be permitted.

**Resolution 2014-10 dated 7-3-2014:**

On any premise having more than one service unit, or business, all of which are serviced by a single meter, the domestic minimum rate shall be multiplied by the number of such service units or businesses taking water from the same meter whether the units are occupied or not. This paragraph does not apply to rooming houses, hotel or motels.

In the case of an existing apartment building or multifamily dwelling where the owner requests separate metering for each unit, the owner is responsible for paying the cost of the required meter and/or meter pit as determined by the Water Works Superintendent. The meters and/or meter pit are then owned and maintained by the Osceola Water Works.

**RULE 15: ACCESS TO PREMISES**

If a customer refuses access as provided herein, or if premises are inaccessible due to the presence of vicious dogs or for other reasons, the Osceola Water Works shall have the right to move such customer's meter to an outside installation or install a remote reading device at the customer's expense. The charge will be the actual cost of materials and labor. Failure to pay such charges shall make the Customer liable for discontinuance of service in the same manner as any other charge owed to the Osceola Water Works.

**RULE 16: WATER METER TESTING POLICY**

**Resolution 2015-01 dated 1-8-2015:**

The Osceola Water Board of Trustees set a water meter testing policy for use when dealing with customer's who request that their water meter be tested for accuracy.

The Osceola Water Works will utilize an independent accredited testing authority of their choice to resolve customer dispute resolution for testing the customer's water meter.

If the outside testing agency determines that the water meter testing results are acceptable within AWWA standards, the customer will be billed for applicable fees which include all costs accrued from the testing agency, shipping costs, and a \$65.00 meter re-installation fee for installing the meter.

If the outside agency determines that the water meter testing results are not acceptable with the AWWA standards, the Osceola Water Works will cover all the applicable meter testing fees.

**RULE 17: EMPLOYEE COMPENSATION FROM CUSTOMERS**

Employees or agents of the Osceola Water Works are expressly forbidden to demand or accept any compensation for any service rendered to its Customers except as covered in the Osceola Water Works Rate Schedule, or Rules and Regulations.

**RULE 18: COMPLAINTS**

Any complaint against the service or employees of the Osceola Water Works should be made at the Osceola Water Works office and preferably in writing.

**RULE 19: RIGHT TO REFUSE SERVICE**

The Osceola Water Works shall have the right to refuse or to discontinue water service to any premise to protect itself against fraud, abuse, or unsafe conditions.

**RULE 20: LOCATION OF WATER INFRASTRUCTURE**

**Resolution 2015-10 dated 3-5-2015:**

**A. Water mains and facilities owned or maintained by the Osceola Water Works:**

The Osceola Water Works will furnish information, as available from its records, regarding locations of mains, hydrants, valves, and other fixtures owned by the Osceola Water Works. The Osceola Water Works will use its employees and tools in this effort at no cost to the person assisted. The Osceola Water Works will assume responsibility for the location of its mains, pipes, valves, or other fixtures. It should be understood that after the location of the facility is established, the Osceola Water Works shall expect the facility to be protected from damage or harm.

**B. Water mains, valves, services and fixtures not owned or maintained by the Osceola Water Works.**

This section references private water mains and valves, benefited water district mains, rural water district mains, etc. On such mains and facilities, the Osceola Water Works will make available to persons who have a reasonable need, information concerning these mains and facilities from records on file with the Osceola Water Works.

The Osceola Water Works will, upon request, provide assistance, at its convenience, in an effort to locate a private water service line, valve, or fixture, but shall not be liable for any loss, damage or injury to person(s) or property arising from providing said service.

Records on private mains and facilities and similar installations are furnished to the Osceola Water Works on behalf of the owners of these mains and facilities and may not be current or reflect as-built conditions. It should be understood that these facilities are not owned or maintained by the Osceola Water Works.

Persons shall use their own discretion when making use of these records of private facilities. The Osceola Water Works makes no assurances of the accuracy or validity of the records or information.

**RULE 21: UNAUTHORIZED USE OF UNMETERED WATER/METER TAMPERING**

Where a water service has been turned off at the curb box or meter pit for any reason, and is subsequently found turned on without proper authority, the Osceola Water Works may discontinue the water service. The water service shall not be reactivated until the customer pays an amount equal to or greater than the termination amount, plus applicable penalties.

First Unauthorized Use            \$200.00, which includes estimated water usage at the applicable rate structure.

Second Unauthorized Use        \$400.00, which includes estimated water usage at the applicable rate structure.

Third & Subsequent Unauthorized Use



Cut water usage at owner's expense. In order to have the water supply reconnected, the owner will be required to authorize the Osceola Water Works to install a meter pit at the owner's expense.

### **Charges for Unauthorized Tap**

If an unauthorized tap is made, Osceola Water Works will excavate and inspect the tap. The property owner will be charged for time and materials spent completing this task including back fill and restoration. Labor will be charged at the current rate documented in this Schedule of Charges. If the tap passes Osceola Water Works inspection, the property owner will be charged any applicable tap fees. The property owner will also be subject to charges of the unauthorized use of water/meter tampering.

If the unauthorized tap does not meet current Osceola Water Works Rules and Regulations and/or material standards, Osceola Water Works will cut the service at the main at the property owner's expense. The property owner will be charged for time and materials completing this task including backfill and restoration. Labor will be charged at the current rates documented in this Schedule of Charges. The property owner will also be subject to charges for the unauthorized use of water/meter tampering.

The discovery of piping bypassing the meter, or tampering with the meter that would allow unauthorized water to be used on the premises of a customer, is in violation of Chapter 714.4, Code of Iowa. The following charges will be made against the customer in such cases:

1. Cost for removal of piping and all other incidental costs
2. A penalty established by the Board
3. The Osceola Water Works reserves the right to charge for estimated water consumption in addition to the above charges.

### **RULE 22: TEMPORARY INTERRUPTION OF SERVICE**

The Osceola Water Works may interrupt a customer's water supply in order to make repairs to the system. An effort will be made to provide 24-hour advance notification of any interruption. In case of emergencies such as a main break, mains or services may be shut down without notification.

The Osceola Water Works shall use reasonable diligence in providing a regular and uninterrupted supply of water, but in case the supply of water is interrupted by reason of storms, fire, accident, breakdown, legal process, interference of higher governmental bodies, or any cause beyond its control, the Water Works shall not be liable for damages to the customer for interruptions in service due to any of the aforesaid causes.

### **RULE 23: TEMPORARY SERVICE**

Any standby, temporary or special service connections installed on order of a customer shall be at the expense of the Customer.

**RULE 24: TEMPORARY DISCONTINUANCE OF UTILITY SERVICES**

Osceola Water Works agrees to provide for a temporary and voluntary discontinuance of utility services for ‘snowbirds’ or those who will not be occupying their residence for period of time of six months or less. In order to have their services placed on “snowbird” status, a customer must present to the Osceola Water Works office the request to have their services disconnected. After the request has been received the Osceola Water Works will disconnect services. If more than one service line is connected to the same curb box, services will not be disconnected as requested until a separate curb box or meter pit is installed. Determination of whether installing a curb box or meter pit is required will be made by the Osceola Water Works and shall be paid by the property owner requesting disconnection. At the time of disconnection, the final bill will be paid for usage consumed and then the Osceola Water Works agrees to bill and collect for the City of Osceola a monthly Sewer convenience fee of \$18.31. Upon notification that the customer has returned, the services will be reinstated and a water reinstatement fee of \$15.00 will be assessed on the next utility bill.

**RULE 25: SERVICE LINE REQUIREMENTS**

**Resolution 2021-13 dated 7-1-2021:**

Service connections and lines to provide regular water service as requested by a customer shall be installed and maintained in accordance with the following:

- A. Application for a new service connection shall be made in writing at the office of the Osceola Water Works by the prospective customer or his agent. The application for water service shall in general clearly outline the permanent location of the premises to be served, the applicant, the owner, the location and size of meters, size of service connection desired, and the scope and type of use to be made of the service.

**Resolution 2017-14 dated 6-8-2017**

- B. For any service line or service connection without a meter pit installed which complies with Osceola Water Works specifications, the customer shall be responsible for maintain and repairing (1) the meter pit and (2) the service line from the premise to the main.
- C. For any service line or service connection with a meter pit installed on private property, the customer shall be responsible for maintaining and repairing (1) the meter pit and (2) the service line from the premise to the main.
- D. Maintenance and repair of all private service lines that do not meet Osceola Water Works specifications shall be the responsibility of the owner from the premise to the main. The Osceola Water Works will not take ownership of service connections with a meter pit installed unless the service connection meets Osceola Water Works specifications in effect at the time of the requested transfer.

- E. All leaks in private water lines that occur must be repaired within seventy-two (72) hours of discovering the leak. Service to the private line will be discontinued if the repair(s) is not completed within the seventy-two (72) hour period.

Depending on the location and severity of the leak, the Water Superintendent or his designee may determine at their discretion that the water leak needs to be repaired before the seventy-two (72) hour requirement.

If a private line serves more than one (1) customer and is not repaired within the prescribed time period the Osceola Water Works may order the needed repair(s) be made and bill the customers served by the private line. The costs may be assessed as a lien against the property as per Iowa code sections 384.62 and 364.12.

- F. If a service connection that is owned by the Osceola Water Works is found to be leaking, the Osceola Water Works may, without notice, repair or turn off same, and the expense of which will be borne by the Water Works.

- G. **Resolution 2015-03 dated 1-8-2015:**

A service connection from the tap in the main shall not be less than three-fourths inch (3/4") in diameter. The service connection shall be type K copper pipe from the main to the curb stop or outside meter pit. The customer's service line from the meter pit or curb stop to the dwelling, only (3/4") type K copper pipe or nothing less than 160-lb. plastic pipe is allowed. Tracer wire must be laid with plastic pipe, 12 gauge single strand. Outside meter pits shall be required on all new or replaced service lines or as determined by the Osceola Water Works as best. Each meter pit will require a 2" pre-drilled hole in the center of the lid so our meter system can be installed. (See Illustration A). All meter pits require tracer wire ran and brought up through the meter pit so the Osceola Water Works can locate both the service connection and the customer service line. The curb box or outside meter pit shall be placed six inches to eighteen inches outside the sidewalk or sidewalk line, at a location on the premises to be determined by the Osceola Water Works. The cover of the box or meter pit shall be maintained at the same height as the sidewalk or surrounding ground.

- H. Corporation Cocks will be tapered AWWWS thread inlet with flared fittings for copper from the corporation cock to the curb stop, or clamped compression fittings.

Clamped compression fittings will not be allowed under concrete.

- I. Any change in the location of an existing service line at the request of the customer will be made at the expense of the customer.

- J. Two section service saddles for plastic mains must be all brass or bronze clamped or all stainless steel wrap around, with brass, bronze, or stainless steel bolts, and must be approved by the Osceola Water Works.

- K. Taps shall **not** be located:

1. Closer together than 18 inches from another tap, joint or pipe fitting

## 2. On hydrant branch

- L. Connections larger than 2" will be made by the installation of a tapping sleeve and valve at the main, or in a similar manner, as prescribed by the Osceola Water Works.
- M. All curb stops will be ¼ turn with stop, ball design, or inverted key design. Stop and waste valves are prohibited. Stainless steel rods are required.
- N. All service connections and lines laid under paving shall be laid to provide a minimum cover of (60"). All other service connections and service lines shall be laid to provide a minimum cover of (48") and shall conform to the grade of any street where such grade has been established by appropriate governmental authority.
- O. The Customer's water service shall be placed in a trench separate from any other utility service trench, all the way from the main to the meter. The undisturbed earth shall not be less than four (4) feet horizontal separation. A shelf cut into the side of a sewer or other utility services, at less depth than the water service trench is not a separate trench within the meaning and requirements of this rule.
- P. Where the Customer's service line is extended into any building or residence, a meter valve (wheel type or approved) shall be installed on the service pipe, at or immediately beyond the point where such service pipe enters the building, and another valve immediately after the meter. The valve before meter will be flare type or compression with restraining clamp, if copper, or securely clamped if Pe. The service shall enter at least 12 inches above floor and proper conduit must be used. The only exception shall be for homes or buildings without basements and then care should be taken to minimize service lines being installed under foundations or cement slabs. These valves must be accessible to the occupant and the Water Works, and maintained in good repair and operating order at all times at the expense of such owner or customer.
- Q. Customers will not be permitted to extend service lines along public or private streets or roadways, in order to obtain connections to the water main. In the event a service connection is requested at a point not already served by a main of adequate capacity, the Osceola Water Works will extend its mains as provided for in these Rules and Regulations. Refer to Rules 30-34.
- R. Customers will not be permitted to extend service lines through the property of another in order to obtain connection to the water main. The Osceola Water Board may grant a variance to this policy if no public street right-of-way exists for extensions of a water main, and if it's impractical or undesirable from the City's standpoint that a public right-of-way main extension be required. In such cases, the customer must provide the board with a lawfully executed and recorded easement across private property granting the customer the authority to extend, maintain and repair the service line.

- S. Service connections for vacant lots or in advance of building requirements, may be made if an unimproved area should require water for construction purposes, truck gardens, or similar usage, or in new subdivisions where final grade is made.

T. **Resolution 2015-02 dated 1-8-2015:**

All service lines and service connections having a ½”, ¾”, 1” or 2” corporation tap that become useless because of laying of larger or other new services, or because of water no longer being used through them, must be permanently disconnected from the corporation stop and the stop box or meter pit removed in accordance with these Rules and Regulations (see Illustration B, page 31) this work shall be performed at the owner’s expense by a plumbing contractor and inspected by Osceola Water Works.

Upon proper application by the customer, approved by Osceola Water Works, an existing service connection having a ½”, ¾”, 1” or 2” corporation tap may be temporarily plugged at the stop box or meter pit with the understanding that the service connection so stubbed must be reused in one year. Such service lines may be stubbed only if the service line is copper and the curb valve or meter pit meets current curb valve or meter pit requirements. A new curb stop or meter pit shall be installed at the time the service line is stubbed if the existing curb stop or meter pit does not meet these standards (see required application, Illustration B-1, page 32). The decision whether a curb stop or meter pit is installed will be at the sole discretion of the Osceola Water Works.

When services are connected to the water main by a tee and gate valve or a tapping sleeve and valve, Osceola Water Works shall require the service to be permanently disconnected from the water main by an approved method determined by Osceola Water Works.

Upon proper application by the customer, approved by Osceola Water Works, an existing water service connection larger than 2 inches may be temporarily plugged with the understanding that the service connection so stubbed must be reused in one year. Such service lines may be stubbed only if the service connection was made using an approved style gate valve (see required application, Illustration B-1, page 32).

- U. The outside curb valve and curb box or outside meter pit shall be under the sole control of the Osceola Water Works, and no one except an employee or person specially authorized by the Osceola Water Works shall open the cover of such box.
- V. Location of meter setting on services will be at determination of the Osceola Water Works. Meters must be accessible at all times to Osceola Water Works personnel in the case of multi-unit apartment buildings where individual households are metered separately. Installation of meters will be located within the premises or in a pit outside at the discretion of the Osceola Water Works, at the expense of the customer.
- W. Customers desiring to have the consumption of water at their premises measured as separate portions according to the use they put it to, may have supplemental meters

installed. In this event the customer shall have had all necessary plumbing done prior to the installation of such a meter. The Osceola Water Works will sell the customer such a meter and install it, after which the customer shall be responsible for maintaining the meter. If future meter upgrades are made to the Osceola Water Works distribution system, the customer will be responsible for purchasing a new meter.

- X. All new service lines and service connections shall be made available for inspection by Osceola Water Works personnel to ensure they meet Osceola Water Works specifications before being accepted. Contact Osceola Water Works office at 641-342-1435 when the installation is ready for an inspection.
  
- Y. After new service lines and service connections are installed, inspected and approved by Osceola Water Works personnel, including setting of the meter pit(s), the Osceola Water Works will take ownership of the service connection from the meter pit to the main. Outside meter pits shall be required on new or replaced service lines at the discretion of the Osceola Water Works. If the determination is made by the Osceola Water Works to have a curb box installed instead of a meter pit, maintenance and repair of the service line will remain the customer's responsibility from the main to the premise.
  
- Z. All maintenance and repair of private service lines that do not meet Osceola Water Works specifications are the responsibility of the owner from the dwelling to the main.

**AA. Resolution 2023-19 dated 7-13-23:**

Galvanized and Lead Service Line Replacement

- 1. Any service line or service connection that contains galvanized iron piping, lead piping, lead fittings, lead fixtures, lead solder, or other lead component; that is discovered, shall be replaced with a water service line of proper size and approved material between the water main and the structure(s) on the premises to be supplied.
  - a. It shall not be lawful to leave any galvanized iron piping, or lead component in the service line.
  
  - b. Where the service line is composed entirely of lead pipe, or consists of a mix of lead and galvanized piping materials, the service line shall be replaced in its entirety, from the point of connection to the Water Works water main to the structure(s) on the premises to be supplied.
  
  - c. Where the service line consists of lead "pigtail" or "gooseneck" between the water main and the curb stop box, and consists of copper or plastic from the curb

stop box to the water meter, only the portion between the water main and the curb stop must be replaced.

- d. The cost of such replacement shall be the responsibility of the property owner.
  - e. The Water Superintendent or his designee shall, if the owner does not act to correct the defect within a specified prescribed time period issued to the property owner, cause the discontinuance of water service to the premises. Any costs incurred by the water utility for excavation and replacement, and repair of damages to property caused by such, shall be charged to the owner and may be assessed as a lien against the property as provided by in sections 384.62 and 364.12 Iowa Code.
2. The Water Superintendent may require replacement of the leaking water services made of other non-approved materials if it is determined that the condition of the service line presents safety or sanitary concerns.

## **RULE 26: HYDRANT FLOW TESTING**

**Resolution 2015-20 dated 9-8-2015.**

Fire hydrant flow tests determine the flow rate and pressure in any location throughout Osceola Water Works underground water distribution system. Fire hydrants are tested regularly to ensure that they are capable of providing water at an acceptable pressure and flow rate for public health and firefighting operations.

Osceola Water Works will, upon request, perform a water hydrant flow testing for a fee of \$160.00 per hydrant per day.

Osceola Water Works must be present at all testing sites. Customers wishing to perform their own testing on hydrants using their own tools, must schedule an appointment with Osceola Water Works and will be charged a minimum fee of \$56.00/hour.

## **RULE 27: USE OF HYDRANT**

**Resolution 2015-21 dated 10-1-2015.**

No person shall open any fire hydrant except for the legitimate purpose of extinguishment of a fire, in which case the use of the hydrant shall be by a member of the fire department or under their direction. Upon completion, notification to the Osceola Water Works Superintendent is required so inspection of each hydrant used can be conducted.

Anyone who shall operate or attempt to operate a fire hydrant without permission of the Osceola Water Works Superintendent may be prosecuted as provided by law and outlined in Schedule of Charges (Schedule A).

Schedule A: (Effective October 1, 2015)

First Unauthorized Use	\$520.00, plus service inspection cost and cost of repairs, if applicable.
Second Unauthorized Use	\$520.00, plus service inspection cost and cost of repairs, if applicable.
Third Unauthorized Use	\$520.00, plus service inspection cost and cost of repairs, if applicable.

**RULE 28: HYDRANT METERS**

**ELIGIBILITY AND REQUIREMENTS**

The Osceola Water Works may issue hydrant meters to qualified contractors or civic organizations when alternate methods of water supply are not available. The Osceola Water Board reserves the right to decline hydrant meter service to any applicant not deemed qualified to meet the requirements of this rule. At the time of application, the applicant shall state the location and purpose for which the meter will be used, the name and telephone number of a contact person, and why water is not available from another source. As used in this rule, “hydrant meter” shall mean and include a hydrant meter together with valves, fittings, and operational tools. All hydrant meters will be handled on a first-come/first-serve basis. City, County, and State projects will be given higher priority. All hydrant meters issued from Osceola Water Works shall be used only in the areas served directly by Osceola Water Works. Contractors desiring to use a hydrant will be required to complete a hydrant permit at the Osceola Water Works office and pay the required deposit. After the deposit is paid, Osceola Water Works employees will set up bulk meter for water usage at a designated hydrant. Please see attached hydrant use form on pages 25-26.

**RULE 29: OBSTRUCTION OF HYDRANTS**

Nothing shall be erected or planted which shall interfere with the use of a fire hydrant. Sufficient clearance shall be maintained around the hydrant to permit easy connection or hoses and full circle operation of the hydrant using regular hydrant wrenches and hose spanners.

**RULE 30: PUBLIC FIRE HYDRANTS**

- A. Extensions to provide service for public fire hydrants will be made only on order issued by the Osceola Water Board.
- B. Public fire hydrants connected to the Osceola Water Works mains shall be of design and size approved by the Water Works. Each hydrant shall have an auxiliary gate valve between it and the main.



### **RULE 31: PRIVATE FIRE HYDRANTS**

Fire hydrants located on privately owned property, or on streets not dedicated for public use, are the responsibility of the owner and are to be used for fire protection only. These hydrants are designated "private fire hydrants". Where it is the owner's intention that these hydrants be used by the public fire department, these hydrants shall conform to the requirements of the Osceola Water Works hydrant specifications and color coding for fire hydrants. Private hydrants installed at the owner's expense, in accordance with these Rules and Regulations, for use by public fire departments, must be reviewed by the Osceola Water Works and the Osceola Fire Department. Replacement of obsolete hydrants and repair or replacement of hydrants, broken parts, or damage caused by physical abuse or improper operation will be done at the owner's expense.

### **RULE 32: PRIVATE FIRE PROTECTION**

The Osceola Water Works will allow connections for private fire protection systems with the conditions, limitations and requirements as listed:

- A. It shall be expressly understood and agreed by and between the parties receiving private fire service that the Osceola Water Works does not assume liability as an insurer of property person, and that any agreement does not contemplate any special service, pressure or capacity of facility other than the ordinary or the changing conditions of the Osceola Water Works as the same exists from day to day.
- B. All materials for such purposes shall be approved by the Water Works and the services must be provided with suitable valves outside of the building under the exclusive control of the Osceola Water Works. The entire cost and expense of furnishing and installing a private fire service connection shall be borne by the owner of the premises. Said service shall be used exclusively for the extinguishment of fires and no connection for domestic, commercial or industrial use may be attached to this fire service unless such connection be authorized by the Osceola Water Works in writing.
- C. Customers desiring private fire service must consult, before installation, with the Osceola Water Works as to the availability of mains and pressure.

### **RULE 33: PENALTIES FOR IMPROPER USE**

When the owners or occupants of any premises are found to be using water from a private fire protection system for purposes other than fire protection, the Osceola Water Works may discontinue fire service. The Osceola Water Works also reserves the right to require the installation of an approved fire line meter, or an additional line and meter, at the owner's expense. A penalty may also be imposed against the property owner at a rate as established by the Board.

**RULE 34: CROSS-CONNECTION**

No physical connection will be allowed between a service line from the mains of the Osceola Water Works and any pipe or tank which shall have contents or polluted, or otherwise questionable character, or which is not a supply approved by the State. Should such a cross-connection be found, the Osceola Water Works will discontinue service to the customer in question unless all physical connections between the two water supplies are immediately severed.

**RULE 35: BACKFLOW PREVENTION**

The customer shall prevent pollutants and contaminants from entering their potable water supply system or the Osceola Water Works distribution mains by backflow or back siphoning.

- A. All water-using devices must be so designed that back siphoning or backflow to the system cannot occur.
- B. Where harmful contaminants or pollutants are used with any device or process connected to the water system, the customer must install and maintain a reduced pressure backflow prevention device.
- C: All permanently installed underground sprinkling systems shall contain a device designed to prevent back siphoning or backflow to the Osceola Water Works distribution system.

**RULE 36: PROHIBITING PRIVATE WATER MAINS**

All private water mains connected to the Osceola Water Works distribution system shall have installed a meter pit, including appropriate valves, at the point of connection to the main as specified by Osceola Water Works at the expense of the customer.

**RULE 37: REPLACING PRIVATE WATERLINES ON PUBLIC PROPERTY**

- A. Customers hooked on to a private water line may petition requesting the Osceola Water Board to replace the existing private water line with a public main meeting Osceola Water Works specifications. The written petition must contain the names and signatures of all customers willing to participate in the project, and a plan showing the location and size of the main to be installed as well as location of the buildings to be served, and all other existing residences, buildings or vacant lots along the route of the new main.
- B. When such petition has been received, the Osceola Water Works shall receive estimates for the cost of the main replacement. If the project is approved by the Osceola Water Board, the Osceola Water Works shall pay for the cost of the following materials: main pipe, valves, fire hydrants, meter pit, curb box, and all other fittings installed for the Osceola Water Work's convenience. Participating customers will be responsible for the contractor's labor costs for installing the water main and water main materials. Each participating customer shall be responsible for

installing their service line from the curb box or meter pit to their dwelling. Each participating customer shall jointly sign a written agreement with the Osceola Water Works and deposit with the Osceola Water Works the total amount of the project minus the cost of materials paid by the Osceola Water Works, and re-hooking of the customer's service line. No interest will be paid on such deposits. The Osceola Water Works Board will follow this policy within budget restraints.

- C. Once the project is completed the Osceola Water Works will provide the participating customers with an itemized report of material and labor costs for the main replacement and will promptly refund all money in excess of actual costs, in proportion to amount paid by participating Customers. If costs exceed the estimate, the participating customers will promptly be billed for the difference in proportion to the amount originally deposited.
- D. As private water lines are discovered and corrected, the water board has authorized the Osceola Water Works staff to issue a credit up to \$500 to the customer as an incentive for correcting the customer(s) private water service line. The customer will be required to provide an itemized statement to the Osceola Water Works they received from the contractor who completed the repairs.
- E. The Osceola Water Works Superintendent or designee will be responsible for overseeing the installation of the water main, valves, hydrants, customer service connections, customer service lines and necessary fittings, and will oversee the sterilization of the system.
- F. All newly installed water mains must meet Osceola Water Works specifications in all respects, and upon inspection by the Osceola Water Works Superintendent or his designee will be accepted by the Osceola Water Works, and thereafter owned and maintained by the Osceola Water Works.
- G. Before the Osceola Water Works will accept ownership of any newly installed water main, all lawfully executed and recorded easements must be obtained.

**RULE 38: WATER MAIN REPLACEMENTS**

All new water mains, either replacing existing lines or extending into new service areas, must meet the following requirements:

- A. Mains must be at least six (6) inches in diameter or larger as determined by the Osceola Water Works, taking into account the potential for future use, and fire protection as recommended by the Fire Underwriters.
- B. Mains must be of cast iron (D.I.) or DR 18 C900 PVC, laid with tracer wire.
- C. Mains must be laid to provide a minimum of five (5) feet of cover.
- D. All main extensions or replacements must extend at least ten (10) feet along the frontage, past the property line of the last property to be served by water.

E. Separation of Water Mains from Sewer Mains

The following requirements are from Iowa DNR's Iowa Wastewater Facilities Design Standards, Chapter 12, Section 12.5.8, "Protection of Water Supplies."

1. "Horizontal Separation of Gravity Sewers from Water Mains: Gravity sewer mains shall be separated from water mains by a horizontal distance of at least 10 feet unless:
    - a. The top of a sewer main is at least 18 inches below the bottom of the water main, and
    - b. The sewer is placed in a separate trench or in the same trench on a bench of undisturbed earth at a minimum horizontal separation of 3 feet from the water main. When it is impossible to obtain the required horizontal clearance of 3 feet and a vertical clearance of 18 inches between sewers and water mains, the sewers must be constructed of water main materials meeting both a minimum pressure rating of 150 psi and the requirements of Sections 8.2 and 8.4 of the 'Iowa Standards for Water Supply Distribution Systems.' However, a linear separation of at least 2 feet shall be provided.
  2. Separation of Sewer Force Mains from Water Mains: Sewer force mains and water mains shall be separated by a horizontal distance of at least 10 feet unless:
    - a. The force main is constructed of water main materials meeting a minimum pressure rating of 150 psi and the requirements of Section 8.2 and 8.4 of the 'Iowa Standards for Water Supply Distribution Systems' and
    - b. the sewer force main is laid at least four linear feet from the water main.
  3. Separation of Sewer and Water Main Crossovers: Vertical separation of sanitary sewers crossing under any water main should be at least 18 inches when measured from the top of the sewer to the bottom of the water main. If physical conditions prohibit the separation, the sewer may be placed not closer than 6 inches below a water main or 18 inches above a water main. The separation distance shall be the maximum feasible in all cases. Where the sewer crosses over or less than 18 inches below a water main one full length of sewer pipe of water main material shall be located so both joints are as far as possible from the water main. The sewer and water pipes must be adequately supported and have watertight joints. A low permeability soil shall be used for backfill material within 10 feet of the point of crossing."
- F. In the case of areas that have been annexed into the corporate limits of the City of Osceola, the Osceola Water Board may accept those mains which were laid to standards existing at the time of construction. Private water mains outside city limits will have appropriate meter and pit, as per Osceola Water Board approval.
- G. Further specifications are available from Osceola Water Works

- H. The Osceola Water Works will update its water mains, replace service connections, service lines and install meter pits as the budget allows.

**RULE 39: EXTENTION OF MAINS WITHIN THE CORPORATE AREA OF THE CITY**

**Resolution 2022-07 dated 2-3-2022:**

The Osceola Water Works will extend its water mains within the corporate area of the City of Osceola under the following terms and conditions:

- A. Water mains will be installed only on streets dedicated for public use and if possible, between the sidewalks and curbs, or in dedicated utility easements.
- B. The subdivider or developer must supply the Osceola Water Works with a plan showing the streets requesting water service and the number of new services anticipated. If the plan is for a new subdivision, it must first be approved by the Osceola Water Works Board of Trustees.
- C. The Osceola Water Works will designate the location and size of the mains and the size and number of hydrants and valves.
- D. The Osceola Water Works will inspect, and oversee the testing and sterilization of the system.
- E. The developer or subdivider is responsible for installing water main extensions according to Osceola Water Works specifications while contracting directly for such installations, and is responsible for paying the costs thereof directly to the contractor. The developer is also responsible for engineering and the obtaining the necessary permits.
- F. The Osceola Water Works may participate in water main extensions to the following extent:
  - 1. If a new residential subdivision is located some distance from an accessible source main, the Osceola Water Works may choose to participate in the cost of installing a main from the source main to the subdivision if potential additional water revenue is sufficient to warrant such participation.
  - 2. If the main extension is to serve commercial or industrial development, the Osceola Water Works may choose to participate in the cost of installing the main if potential for additional water revenue is sufficient to warrant such participation.
  - 3. In certain cases the Osceola Water Works may choose to be the contracting agent in the installation of water main extensions.

4. **Materials Requirements:** PIPE: Polyvinyl chloride pipe (PVC)-AWWA C900 DR18 OD same as ductile 150 psi working pressure or ductile class 51 or 52.
5. **Fittings:** Mechanical Joint, ductile, min. 150 psi-Tyler, Clow or equal.
6. **Valves:** Non-rising stems, gate, with 2” operating nut, open counter-clockwise, double disc bronze or resilient seat. Mueller, American Flow ductile or equal.
7. **Hydrants:** Hydrants should comply with AWWA C502. Locate fire hydrants between street intersections to provide spacing’s of no more than 450 feet in single family residential districts and no more than 300 feet in all other districts. Mueller Centurion, Clow Medallion or Waterous Pacer, (traffic model), 2-2 1/2” hose nozzle and 1-4 1/2” pumper, National Standard threads. Operating nut pent-1 1/2” point to flat, open counter-clockwise, 6” min. (5 1/4-5’6” bury min.
8. **Tapping “T” & Valve:** MJ tapping sleeve, CI or ductile construction. PVC main all stainless tapping sleeve.
9. **Disinfection/Bacterial Sampling:**

**Resolution 2020-06 dated 4-2-2020**

The form of chlorine used and the procedures for disinfection shall be as outlined in AWWA Standard C-651. A minimum free residual chlorine concentration of 10 mg/1 shall be maintained for the 24-hour disinfection period. The plumbing contractor will supply the chlorine for disinfection purposes, and this is to be considered incidental to the project. After the 24-hour disinfection period, the service main shall be flushed to remove all free chlorine. Twenty-four hours after the service main has been flushed, a sample of water from the service main shall be taken to be tested for compliance with the physical, chemical, and bacteriological standards as prescribed by the National Interim Primary Drinking Water Standards. Twenty-four hours after the 1<sup>st</sup> set of bacterial samples were taken, a second set must be collected. Collection of samples will be conducted by the Osceola Water Works, sent to a certified lab chosen by the Osceola Water Works. A lab cost of \$60.00 will be billed by the Osceola Water Works to the contractor per each bacterial sample collected. Water used for flushing and sampling shall be provided by the Osceola Water Works for up to 2 flushing and sampling procedures, if required, to pass laboratory tests. If the first two samples do not pass laboratory tests, any labor and equipment costs incurred by the Osceola Water Works for further disinfection, flushing, or sampling shall be billed to the plumbing contractor.

10. **Pressure and leak testing:** After your two consecutive sets of acceptable bacteria samples have been completed, a required pressure test will be conducted by the contractor. Isolate new piping from the existing water system. Fill and flush all new piping with potable water. Ensure all trapped

air is removed. Pressurize the new pipe to the test pressure at the highest point in the isolated system. Do not pressurize to more than 5 psi over the test pressure at the highest point in the isolated system. Test and monitor the completed piping system at 1.5 times the system working pressure or 150 psi, whichever is greater, for 2 continuous hours. If at any time during the test the pressure drops to 5 psi below the test pressure, repressurize the pipe by pumping in potable water in sufficient quantity to bring the pressure back to the original test pressure. Accurately measure the amount of water required to repressurize the system to the test pressure.

Maximum allowable leakage rate according to AWWA C600:

$$L = \frac{(S)(D)(P) 0.5}{148,000}$$

Where:

L = allowable leakage, in gallons per hour

S = length of pipe tested, in feet

D = nominal pipe diameter, in inches

P = average test pressure, in pounds per square inch

The following table assumes an average test pressure (P) of 150 psi and 1,000 feet of test section.

#### **Maximum Allowable Leakage Rate**

##### **Pipe Diameter**

**(inches)**

##### **Allowable Leakage Rate**

**(gallons/hour/1,000 feet of pipe)**

4) 0.33

6) 0.50

8) 0.66

10) 0.83

12) 0.99

14) 1.16

16) 1.32

18) 1.49

20) 1.66

24) 1.99

30) 2.48

36) 2.98

If the average measured leakage per hour exceeds the maximum allowable leakage rate, repair and retest the water main. If the measured pressure loss does not exceed 5 psi, the test will be considered acceptable. Repair all visible leaks regardless of the amount of leakage.

11. **Pipe Installation:** Hand shape to provide uniform bearing and support for full length of pipe barrel against undisturbed earth for at least ¼ circumference.

Provide suitable bell holes at each pipe joint after bottom of trench has been graded. Alternative to hand shaping trench bottom, excavate to full depth by

machine then place sand or fine rock (3/8 minus) in trench to provide depth equal to ½ circumference of pipe.

Crushed stone for backfill whenever crossing paved surface, gravel driveway, etc.

12. **Thrust Blocks:** Provide poured concrete thrust blocks when piping changes direction of dead ends. Carry thrust block to undisturbed edge of trench for bearing. Concrete thrust blocks can be used when poured concrete is not available. Minimum thickness of thrust blocks is 18” or as directed by Osceola Water Works. Polyethylene wrap should be wrapped around the pipe, including the bolt circle, before the concrete is placed.
13. **Valve Installation:** Install with stem vertical and centered in valve box. Check all valve bolts when installed, support valves (cement pad, etc.). Carefully tamp earth around valve to undisturbed earth of trench.
14. **Hydrant Installation:** Install plumb, set at elevation so that cover will not be less than adjacent main. Set on concrete pad. Drainback material placed around base of hyd. (pea rock etc.). Block hydrant in place.

#### **RULE 40: SERVICE OUTSIDE OF CITY LIMITS**

The Osceola Water Works will serve customers beyond the corporate limits of Osceola only under the following conditions:

- A. To single-family residence on property adjacent to a public right-of-way containing an existing public water main, provided the lot has at least 660 feet of frontage and is at least ten acres in area.
- B. To industries which, due to environmental or economic reasons, cannot be feasibly located within the City limits of Osceola.
- C. To incorporated rural water districts of ten or more customers, or incorporated cities.

#### **RULE 41: RIGHTS RESERVED**

The Osceola Water Works reserves the right at any time to alter or amend or add to its Rules and Regulations, or to substitute other Rules and Regulations therefor, and such changes shall become effective immediately upon approval by the Osceola Water Works Board of Trustees.



# HYDRANT PERMIT

## Eligibility & Requirements:

The Osceola Water Works may issue hydrant meters to qualified contractors or civic organizations when alternate methods of water supply are not available. The Water Board reserves the right to decline hydrant meter service to any applicant not deemed qualified to meet the requirements of this rule. The applicant shall state the location and purpose for which the meter will be used and the name and telephone number of the contact person. All hydrant meters will be handled on a first come first serve basis. City, county and state projects will be given higher priority. It is the responsibility of the applicant to use the hydrant meter in a safe and proper manner and to keep the hydrant meter secured at all times even when it is not in use.

Osceola Water Works may provide hydrant meters as long as the temperatures allow for usage without causing harm to the meter(s). Osceola Water Works reserves the right at any time to remove the meter when deemed necessary to protect from adverse weather conditions without notice to the permit holder.

- I. This Permit is hereby entered into on this \_\_\_\_\_ day of \_\_\_\_\_, \_\_\_\_\_ by and between \_\_\_\_\_, hereinafter referred to as the "Contractor" and the Osceola Water Works, hereinafter referred to as the "Water Works". The purpose of this permit is to allow the Contractor use of the Water Work's portable fire hydrant meter assembly, in order to provide the Contractor with ease of access to water and provide the Water Works with security and accurate flow recording for equitable billing.
- II. The Contractor, upon signing of this Permit, shall submit to the Water Works a certified check or money order payable to the Osceola Water Works, in the amount of \$2,300.00 to be held as a deposit until completion of the project. Said deposit shall be for the purpose of insuring payment for water used, and to reimburse the Water Works for any damages including but not limited to; damage to the fire hydrant, meter assembly, or damage to water mains in the immediate area caused as a direct result of the "Contractor" use of the hydrant.
- III. The decision regarding location of the meter assembly will be at the sole discretion of the Water Works Superintendent or his designee, and will be based on proximity to the project and condition of the water mains and hydrants in this area. After the location is identified for the contractor, the portable meter assembly will be locked and connected to the hydrant. It is the responsibility of the contractor to lock and/or protect the discharge side of the meter assembly.
- IV. The meter shall then be read and billed monthly by the Water Works to the contractor. All water consumed through the meter will be charged at the current bulk rate. A \$50.00 monthly meter availability charge will be assessed. If the meter is used less than a month, the availability charge will be \$15.00 weekly.
- V. Payment shall be due no later than 30 days after the billing date. Failure to pay timely will result in forfeiture of the meter. Upon completion of the project, the

deposit will be returned minus water usage owed or any damages incurred to the hydrant, meter assembly or water mains.

PROJECT DESCRIPTION AND LOCATION:

---

---

---

Planned Start Date: \_\_\_\_\_ Project Completion Date: \_\_\_\_\_

Signed: \_\_\_\_\_ Date: \_\_\_\_\_

Billing Contact: \_\_\_\_\_

Billing Address:

---

---

---

Telephone Number: \_\_\_\_\_

---

Signed: \_\_\_\_\_ Date: \_\_\_\_\_

---

*For Completion by The Osceola Water Works*

*Water Works Meter #:* \_\_\_\_\_

Date Meter Connected to Hydrant \_\_\_\_\_

Beginning Meter Read:

---

Date Meter Returned to Water Works: \_\_\_\_\_

Final Meter

Read: \_\_\_\_\_

Date of Inspection \_\_\_\_\_

Inspection Completed By: \_\_\_\_\_

Inspection Results: Any Noted Damage? \_\_\_\_\_ Yes, \_\_\_\_\_ No (if yes, provide details below)

---

---

MUELLER / HUNT  
 15-Inch Diameter Coil Single Meter Pit  
 for 5/8" x 3/4" Meter  
 203CS1560LSBN

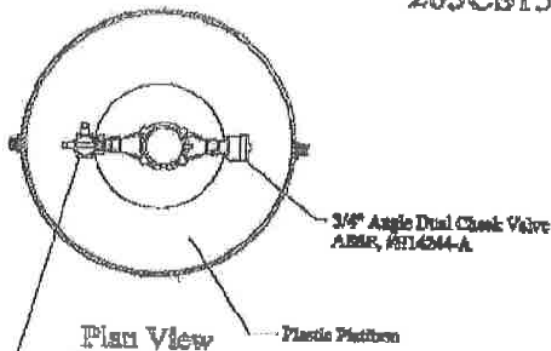

NOTE:  
 Meter Not Included.

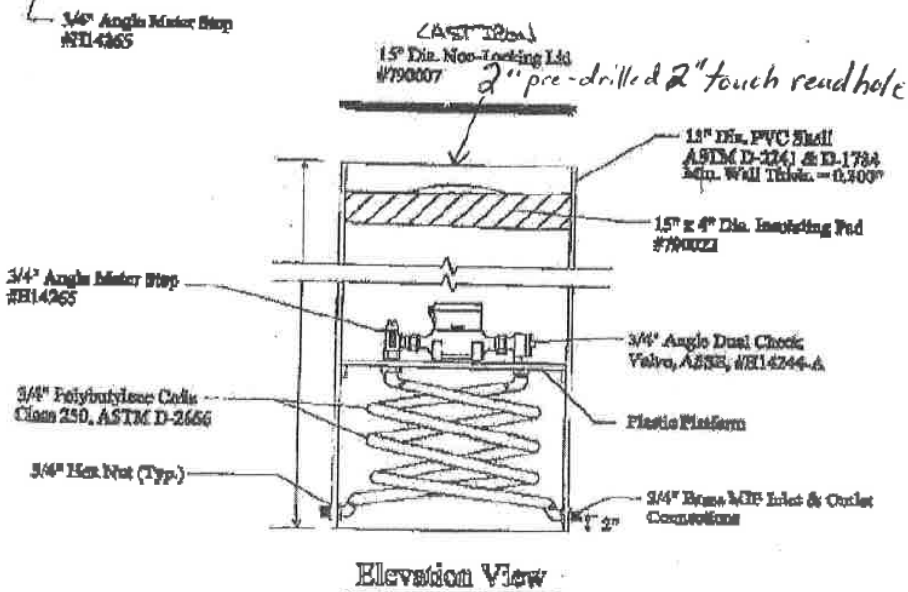

203CS1560LSBN.dwg

REV.	DATE	BY	CHKD.	DESCRIPTION
1	10/15/00	J. J. [unclear]	[unclear]	[unclear]
2	10/15/00	[unclear]	[unclear]	[unclear]

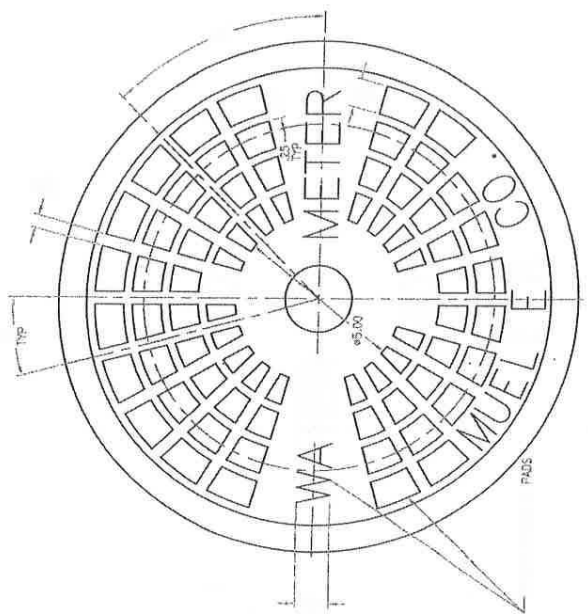
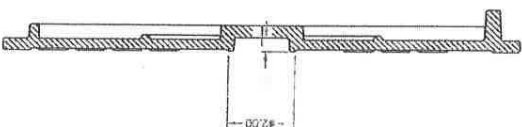
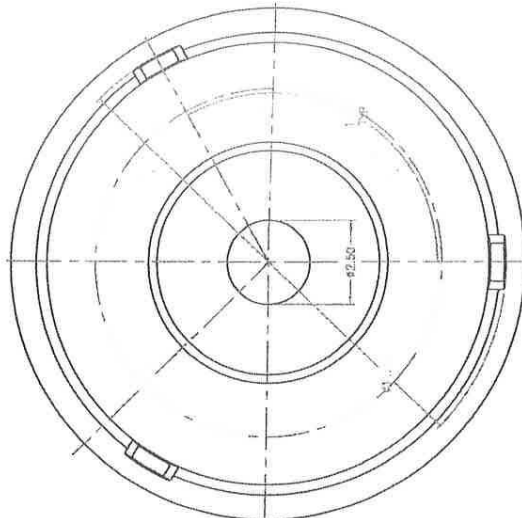

TOLERANCES - UNLESS OTHERWISE NOTED		DATE	10/15/00
DIMENSIONS - UNLESS OTHERWISE NOTED		BY	J. J. [unclear]
MATERIALS - UNLESS OTHERWISE NOTED		CHKD.	[unclear]
FINISHES - UNLESS OTHERWISE NOTED		DATE	10/15/00
TITLES - UNLESS OTHERWISE NOTED		BY	[unclear]
DRAWING NO. 200007		CHKD.	[unclear]
SHEET NO. 1		DATE	10/15/00
SCALE 1:1		BY	[unclear]
DESIGNED BY [unclear]		CHKD.	[unclear]
DRAWN BY [unclear]		DATE	10/15/00
CHECKED BY [unclear]		BY	[unclear]
APPROVED BY [unclear]		DATE	10/15/00

**Illustration B**

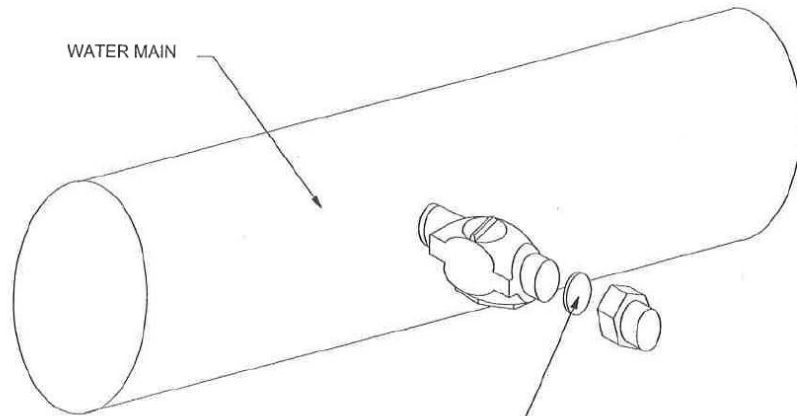

WATER MAIN

WASHER  
(PLUMBERS CAP  
MAY BE USED)

CLOSE CORPORATION. CUT LINE  
FLUSH WITH NUT. PLACE WASHER  
BETWEEN NUT & CORPORATION.  
CURB STOP VALVE TO BE REMOVED  
WHEN APPLICABLE.

Illustration B-1

APPLICATION TO STUB AND REUSE WATER SERVICE LINE

DATE: \_\_\_\_\_ TO: OSCEOLA WATER WORKS

FROM : \_\_\_\_\_

MAILING ADDRESS: \_\_\_\_\_

I AM THE OWNER/AGENT OR OWNER OF THE PROPERTY OR PROPERTIES KNOWN AS:

\_\_\_\_\_  
(SERVICE ADDRESS)

I understand it is my obligation as Owner of this property to maintain water service lines from the water main in accordance with Osceola Water Works' Rules and Regulations and local Plumbing Code. I further understand it is my obligation as Owner of this property to cause a service line to be disconnected at the water main upon the discontinuance of service through such service line. Service to the above described property(s) has been discontinued at my request. Because I expect to reactivate the service not more than one year after the field inspection date listed below, I hereby request that Osceola Water Works excuse me from disconnecting the service at the main at this time, and in consideration of their approval for doing so I agree that the service line will be reactivated within one year. If the service line is not reactivated within one year after the field inspection date listed below, I will have the service line disconnected at the main by a licensed plumber or I hereby authorize Osceola Water Works to disconnect such service line at my expense. I understand such an agreement is contingent upon Water Works review of the following in the field:

- Stub must be copper and must tap in front of the property to be served.
- There may be only one cap (no bullheaded service lines), and it must be 3/4" or larger.
- The service must be large enough to serve the proposed use of the property.
- There must not be a conditions of service on the account due to a leak or needed repair.

Requested Field Inspection Date & Time: \_\_\_\_\_

Owner/Agent Information:

Name: \_\_\_\_\_ Signature: \_\_\_\_\_

Date: \_\_\_\_\_ Contact Telephone #: \_\_\_\_\_

Complete and fax to Osceola Water Works at 641-342-1588 two business days prior to requested field inspection date. *Application must be approved prior to service line being stubbed.*